

enCoRe™ V Low Voltage Microcontroller

Features

- Powerful Harvard Architecture processor
 - M8C processor speeds running up to 24 MHz
 - Low power at high processing speeds
 - Interrupt controller
 - 1.71 V to 3.6 V operating voltage
 - Commercial temperature range: 0 °C to +70 °C
- Flexible on-chip memory
 - Up to 32 K flash program storage
 - 50,000 erase and write cycles
 - Flexible protection modes
 - Up to 2048 bytes SRAM data storage
 - In-system serial programming (ISSP)
- Complete development tools
 - Free development tool (PSoC® Designer™)
 - Full-featured, in-circuit emulator and programmer
 - Full-speed emulation
 - Complex breakpoint structure
 - 128 K trace memory
- Precision, programmable clocking
 - Crystal-less oscillator with support for an external crystal or resonator
 - Internal ±5.0% 6, 12, or 24 MHz main oscillator
 - Internal low-speed oscillator at 32 kHz for watchdog and sleep. The frequency range is 19 to 50 kHz with a 32 kHz typical value
- Programmable pin configurations
 - Up to 36 GPIO (depending on package)
 - 25 mA sink current on all GPIO
 - Pull-up, High Z, open drain, CMOS drive modes on all GPIO
 - CMOS drive mode (5 mA source current) on Ports 0 and 1:
 - 20 mA (at 3.0 V) total source current
 - Low dropout voltage regulator for Port 1 pins:
 - Programmable to output 3.0, 2.5, or 1.8V
 - Selectable, regulated digital I/O on Port 1
 - Configurable input threshold for Port 1
 - Hot-swappable capability on Port 1
- Additional system resources
 - Configurable communication speeds
 - I²C Slave
 - Selectable to 50 kHz, 100 kHz, or 400 kHz
 - Implementation requires no clock stretching
 - Implementation during sleep modes with less than 100 mA
 - Hardware address detection
 - SPI master and SPI slave
 - Configurable between 46.9 kHz and 12 MHz
 - Three 16-bit timers
 - 10-bit ADC used to monitor battery voltage or other signals with external components
 - Watchdog and sleep timers
 - Integrated supervisory circuit

enCoRe V LV Block Diagram

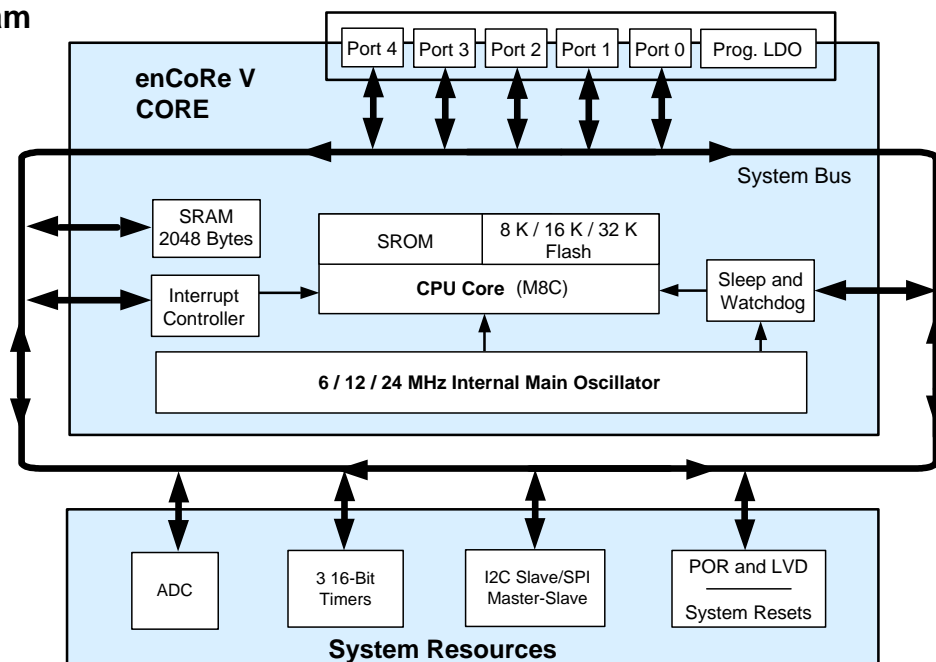

Errata: For information on silicon errata, see "Errata" on page 33. Details include trigger conditions, devices affected, and proposed workaround.

Contents

Functional Overview	3	Electrical Specifications	16
The enCoRe V LV Core	3	Absolute Maximum Ratings	17
10-bit ADC	3	Operating Temperature	17
SPI	4	DC Electrical Characteristics	18
I2C Slave	4	AC Electrical Characteristics	23
Additional System Resources	5	Package Diagram	28
Getting Started	5	Packaging Dimensions	28
Application Notes	5	Package Handling	30
Development Kits	5	Thermal Impedances	30
Training	5	Capacitance on Crystal Pins	30
CYPros Consultants	5	Solder Reflow Peak Temperature	30
Solutions Library	5	Ordering Information	31
Technical Support	5	Ordering Code Definitions	31
Development Tools	6	Acronyms	32
PSoC Designer Software Subsystems	6	Document Conventions	32
Designing with PSoC Designer	7	Units of Measure	32
Select User Modules	7	Errata	33
Configure User Modules	7	CY7C604xx Errata Summary	33
Organize and Connect	7	Document History Page	34
Generate, Verify, and Debug	7	Sales, Solutions, and Legal Information	37
Pin Configuration	8	Worldwide Sales and Design Support	37
16-Pin Part Pinout	8	Products	37
32-Pin Part Pinout	9	PSoC® Solutions	37
48-Pin Part Pinout	11	Cypress Developer Community	37
Register Reference	13	Technical Support	37
Register Conventions	13		
Register Mapping Tables	13		

Functional Overview

The enCoRe V LV family of devices are designed to replace multiple traditional low voltage microcontroller system components with one, low cost single chip programmable component. Communication peripherals (I²C/SPI), a fast CPU, flash program memory, SRAM data memory, and configurable I/O are included in a range of convenient pinouts.

The architecture for this device family, as illustrated in [enCoRe V LV Block Diagram](#), is comprised of two main areas: the CPU core and the system resources. Depending on the enCoRe V LV package, up to 36 GPIO are also included.

Enhancements over the Cypress's legacy low-voltage microcontrollers include faster CPU at lower voltage operation, lower current consumption, twice the RAM and flash, hot-swappable I/Os, I²C hardware address recognition, new very low-current sleep mode, and new package options.

The enCoRe V LV Core

The enCoRe V LV Core is a powerful engine that supports a rich instruction set. It encompasses SRAM for data storage, an interrupt controller, sleep and watchdog timers, and IMO (internal main oscillator) and ILO (internal low-speed oscillator). The CPU core, called the M8C, is a powerful processor with speeds up to 24 MHz. The M8C is a four-MIPS, 8-bit Harvard architecture microprocessor.

System Resources provide additional capability, such as a configurable I²C slave and SPI master-slave communication interface and various system resets supported by the M8C.

10-bit ADC

The ADC on enCoRe V LV device is an independent block with a state machine interface to control accesses to the block. The ADC is housed together with the temperature sensor core and can be connected to this or the Analog Mux Bus. As a default operation, the ADC is connected to the temperature sensor diodes to give digital values of the temperature.

Figure 1. ADC System Performance Block Diagram

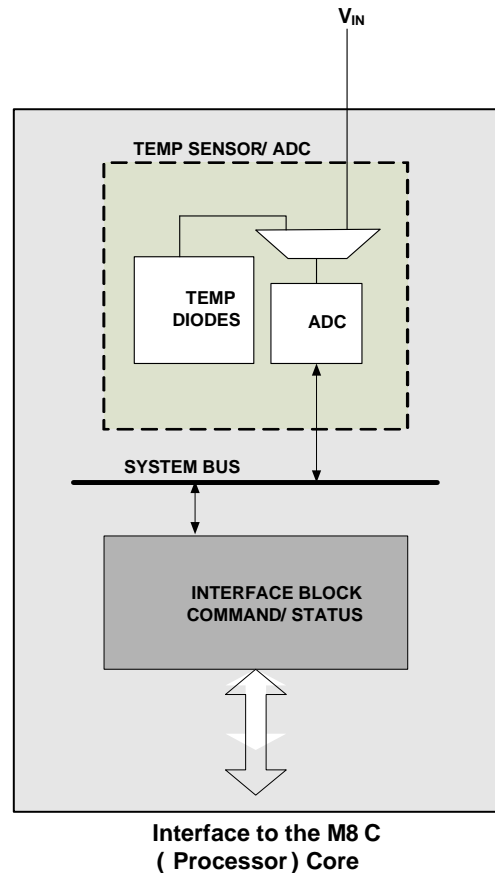

The ADC User Module contains an integrator block and one comparator with positive and negative input set by the MUXes. The input to the integrator stage comes from the Analog Global Input Mux or the temperature sensor with an input voltage range of 0 V to 1.3 V, where 1.3 V is 72% of full scale.

In the ADC only configuration (the ADC MUX selects the Analog Mux Bus, not the default temperature sensor connection), an external voltage can be connected to the input of the modulator for voltage conversion. The ADC is run for a number of cycles set by the timer, depending upon the resolution of the ADC desired by the user. A counter counts the number of trips by the comparator, which is proportional to the input voltage. The Temp Sensor block clock speed is 36 MHz and is divided down to 1 to 12 MHz for ADC operation.

SPI

The serial peripheral interconnect (SPI) 3-wire protocol uses both edges of the clock to enable synchronous communication without the need for stringent setup and hold requirements.

Figure 2. Basic SPI Configuration

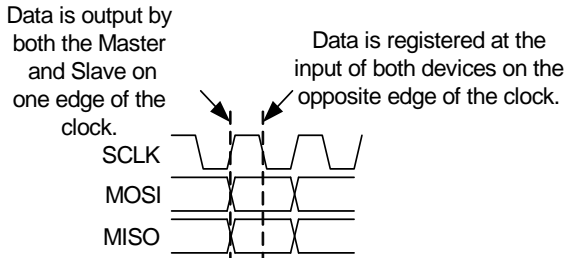

A device can be a master or slave. A master outputs clock and data to the slave device and inputs slave data. A slave device inputs clock and data from the master device and outputs data for input to the master. Together, the master and slave are essentially a circular Shift register, where the master generates the clocking and initiates data transfers.

A basic data transfer occurs when the master sends eight bits of data, along with eight clocks. In any transfer, both master and slave transmit and receive simultaneously. If the master only sends data, the received data from the slave is ignored. If the master wishes to receive data from the slave, the master must send dummy bytes to generate the clocking for the slave to send data back.

Figure 3. SPI Block Diagram

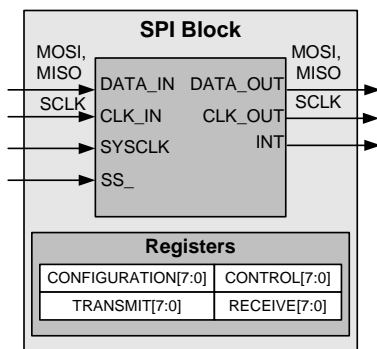

SPI configuration register (SPI_CFG) sets master/slave functionality, clock speed and interrupt select. SPI control register (SPI_CR) provides four control bits and four status bits for device interfacing and synchronization.

The SPIM hardware has no support for driving the Slave Select (SS_) signal. The behavior and use of this signal is application and enCoRe V device dependent and, if required, must be implemented in firmware.

There is an additional data input in the SPIS, Slave Select (SS_), which is an active low signal. SS_ must be asserted to enable the SPIS to receive and transmit. SS_ has two high level functions: 1) To allow for the selection of a given slave in a multi-slave environment, and 2) To provide additional clocking for TX data queuing in SPI modes 0 and 1.

I²C Slave

The I²C slave enhanced communications block is a serial-to-parallel processor, designed to interface the enCoRe V LV device to a two-wire I²C serial communications bus. To eliminate the need for excessive CPU intervention and overhead, the block provides I²C-specific support for status detection and generation of framing bits. By default, the I²C Slave Enhanced module is firmware compatible with the previous generation of I²C slave functionality. However, this module provides new features that are configurable to implement significant flexibility for both internal and external interfacing.

Figure 4. I²C Block Diagram

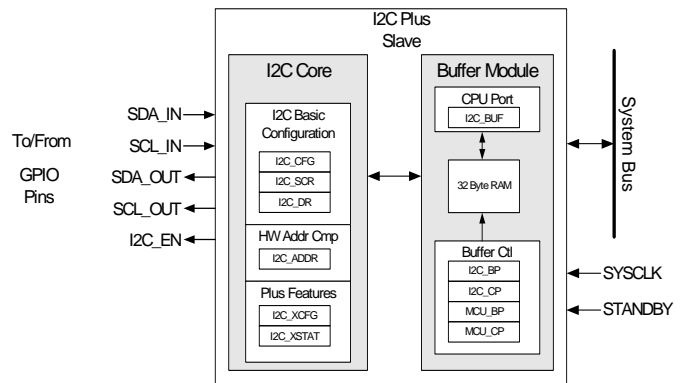

The basic I²C features include:

- *Slave, transmitter, and receiver operation
- *Byte processing for low CPU overhead
- *Interrupt or polling CPU interface
- *Support for clock rates of up to 400 kHz
- *7- or 10-bit addressing (through firmware support)
- *SMBus operation (through firmware support)

Enhanced features of the I²C Slave Enhanced Module include:

- *Support for 7-bit hardware address compare
- *Flexible data buffering schemes
- *A 'no bus stalling' operating mode
- *A low power bus monitoring mode

The I²C block controls the data (SDA) and the clock (SCL) to the external I²C interface through direct connections to two dedicated GPIO pins. When I²C is enabled, these GPIO pins are not available for general purpose use. The enCoRe V LV CPU firmware interacts with the block through I/O register reads and writes, and firmware synchronization is implemented through polling and/or interrupts.

In the default operating mode, which is firmware compatible with previous versions of I²C slave modules, the I²C bus is stalled upon every received address or byte, and the CPU is required to read the data or supply data as required before the I²C bus continues. However, this I²C Slave Enhanced module provides new data buffering capability as an enhanced feature. In the EZI²C buffering mode, the I²C slave interface appears as a 32-byte RAM buffer to the external I²C master. Using a simple predefined protocol, the master controls the read and write pointers into the RAM. When this method is enabled, the slave never stalls the bus. In this protocol, the data available in the RAM (this is managed by the CPU) is valid.

Additional System Resources

System Resources, some of which have been previously listed, provide additional capability useful to complete systems. Additional resources include low voltage detection and power on reset. The following statements describe the merits of each system resource:

- Low-voltage detection (LVD) interrupts can signal the application of falling voltage levels, while the advanced power-on reset (POR) circuit eliminates the need for a system supervisor.
- The 3.6 V maximum input, 1.8, 2.5, or 3 V selectable output, low dropout regulator (LDO) provides regulation for I/Os. A register controlled bypass mode enables the user to disable the LDO.
- Standard Cypress PSoC IDE tools are available for debugging the enCoRe V LV family of parts.

Getting Started

The quickest way to understanding the enCoRe V silicon is by reading this datasheet and using the PSoC Designer Integrated Development Environment (IDE). This datasheet is an overview of the enCoRe V integrated circuit and presents specific pin, register, and electrical specifications. For in-depth information, along with detailed programming information, refer to the *PSoC Programmable System-on-Chip Technical Reference Manual*, for CY8C28xxx PSoC devices.

For up-to-date ordering, packaging, and electrical specification information, reference the latest enCoRe V device datasheets on the web at <http://www.cypress.com>.

Application Notes

[Cypress application notes](#) are an excellent introduction to the wide variety of possible PSoC designs.

Development Kits

[PSoC Development Kits](#) are available online from and through a growing number of regional and global distributors, which include Arrow, Avnet, Digi-Key, Farnell, Future Electronics, and Newark.

Training

[Free PSoC technical training](#) (on demand, webinars, and workshops), which is available online via www.cypress.com, covers a wide variety of topics and skill levels to assist you in your designs.

CYPros Consultants

Certified PSoC consultants offer everything from technical assistance to completed PSoC designs. To contact or become a PSoC consultant go to the [CYPros Consultants](#) web site.

Solutions Library

Visit our growing [library of solution focused designs](#). Here you can find various application designs that include firmware and hardware design files that enable you to complete your designs quickly.

Technical Support

[Technical support](#) – including a searchable Knowledge Base articles and technical forums – is also available online. If you cannot find an answer to your question, call our Technical Support hotline at 1-800-541-4736.

Development Tools

PSoC Designer™ is the revolutionary integrated design environment (IDE) that you can use to customize PSoC to meet your specific application requirements. PSoC Designer software accelerates system design and time to market. Develop your applications using a library of precharacterized analog and digital peripherals (called user modules) in a drag-and-drop design environment. Then, customize your design by leveraging the dynamically generated application programming interface (API) libraries of code. Finally, debug and test your designs with the integrated debug environment, including in-circuit emulation and standard software debug features. PSoC Designer includes:

- Application editor graphical user interface (GUI) for device and user module configuration and dynamic reconfiguration
- Extensive user module catalog
- Integrated source-code editor (C and assembly)
- Free C compiler with no size restrictions or time limits
- Built-in debugger
- In-circuit emulation
- Built-in support for communication interfaces:
 - Hardware and software I²C slaves and masters
 - Full-speed USB 2.0
 - Up to four full-duplex universal asynchronous receiver/transmitters (UARTs), SPI master and slave, and wireless

PSoC Designer supports the entire library of PSoC 1 devices and runs on Windows XP, Windows Vista, and Windows 7.

PSoC Designer Software Subsystems

Design Entry

In the chip-level view, choose a base device to work with. Then select different onboard analog and digital components that use the PSoC blocks, which are called user modules. Examples of user modules are analog-to-digital converters (ADCs), digital-to-analog converters (DACs), amplifiers, and filters. Configure the user modules for your chosen application and connect them to each other and to the proper pins. Then generate your project. This prepopulates your project with APIs and libraries that you can use to program your application.

The tool also supports easy development of multiple configurations and dynamic reconfiguration. Dynamic reconfiguration makes it possible to change configurations at run time. In essence, this lets you to use more than 100 percent of PSoC's resources for an application.

Code Generation Tools

The code generation tools work seamlessly within the PSoC Designer interface and have been tested with a full range of debugging tools. You can develop your design in C, assembly, or a combination of the two.

Assemblers. The assemblers allow you to merge assembly code seamlessly with C code. Link libraries automatically use absolute addressing or are compiled in relative mode, and linked with other software modules to get absolute addressing.

C Language Compilers. C language compilers are available that support the PSoC family of devices. The products allow you to create complete C programs for the PSoC family devices. The optimizing C compilers provide all of the features of C, tailored to the PSoC architecture. They come complete with embedded libraries providing port and bus operations, standard keypad and display support, and extended math functionality.

Debugger

PSoC Designer has a debug environment that provides hardware in-circuit emulation, allowing you to test the program in a physical system while providing an internal view of the PSoC device. Debugger commands allow you to read and program and read and write data memory, and read and write I/O registers. You can read and write CPU registers, set and clear breakpoints, and provide program run, halt, and step control. The debugger also lets you to create a trace buffer of registers and memory locations of interest.

Online Help System

The online help system displays online, context-sensitive help. Designed for procedural and quick reference, each functional subsystem has its own context-sensitive help. This system also provides tutorials and links to FAQs and an Online Support Forum to aid the designer.

In-Circuit Emulator

A low-cost, high-functionality in-circuit emulator (ICE) is available for development support. This hardware can program single devices.

The emulator consists of a base unit that connects to the PC using a USB port. The base unit is universal and operates with all PSoC devices. Emulation pods for each device family are available separately. The emulation pod takes the place of the PSoC device in the target board and performs full-speed (24 MHz) operation.

Designing with PSoC Designer

The development process for the PSoC device differs from that of a traditional fixed-function microprocessor. The configurable analog and digital hardware blocks give the PSoC architecture a unique flexibility that pays dividends in managing specification change during development and lowering inventory costs. These configurable resources, called PSoC blocks, have the ability to implement a wide variety of user-selectable functions. The PSoC development process is:

1. Select [user modules](#).
2. Configure user modules.
3. Organize and connect.
4. Generate, verify, and debug.

Select User Modules

PSoC Designer provides a library of prebuilt, pretested hardware peripheral components called “user modules.” User modules make selecting and implementing peripheral devices, both analog and digital, simple.

Configure User Modules

Each user module that you select establishes the basic register settings that implement the selected function. They also provide parameters and properties that allow you to tailor their precise configuration to your particular application. For example, a PWM User Module configures one or more digital PSoC blocks, one for each eight bits of resolution. Using these parameters, you can establish the pulse width and duty cycle. Configure the parameters and properties to correspond to your chosen application. Enter values directly or by selecting values from drop-down menus. All of the user modules are documented in datasheets that may be viewed directly in PSoC Designer or on the Cypress website. These [user module datasheets](#) explain the internal operation of the user module and provide performance specifications. Each datasheet describes the use of each user module parameter, and other information that you may need to successfully implement your design.

Organize and Connect

Build signal chains at the chip level by interconnecting user modules to each other and the I/O pins. Perform the selection, configuration, and routing so that you have complete control over all on-chip resources.

Generate, Verify, and Debug

When you are ready to test the hardware configuration or move on to developing code for the project, perform the “Generate Configuration Files” step. This causes PSoC Designer to generate source code that automatically configures the device to your specification and provides the software for the system. The generated code provides APIs with high-level functions to control and respond to hardware events at run time, and interrupt service routines that you can adapt as needed.

A complete code development environment lets you to develop and customize your applications in C, assembly language, or both.

The last step in the development process takes place inside PSoC Designer’s Debugger (accessed by clicking the Connect icon). PSoC Designer downloads the HEX image to the ICE where it runs at full-speed. PSoC Designer debugging capabilities rival those of systems costing many times more. In addition to traditional single-step, run-to-breakpoint, and watch-variable features, the debug interface provides a large trace buffer. It lets you to define complex breakpoint events that include monitoring address and data bus values, memory locations, and external signals.

Pin Configuration

16-Pin Part Pinout

Figure 5. CY7C60413 16-Pin enCoRe V LV Device

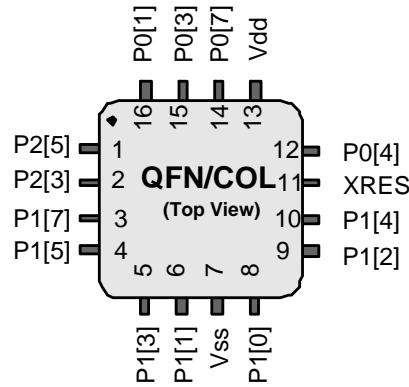

Table 1. 16-Pin Part Pinout (QFN)

Pin No.	Type	Name	Description
1	I/O	P2[5]	Digital I/O, crystal out (Xout)
2	I/O	P2[3]	Digital I/O, crystal in (Xin)
3	IOHR	P1[7]	Digital I/O, I ² C SCL, SPI SS
4	IOHR	P1[5]	Digital I/O, I ² C SDA, SPI MISO
5	IOHR	P1[3]	Digital I/O, SPI CLK
6	IOHR	P1[1] ^(1, 2)	Digital I/O, ISSP CLK, I ² C SCL, SPI MOSI
7	Power	Vss	Ground pin
8	IOHR	P1[0] ^(1, 2)	Digital I/O, ISSP DATA, I ² C SDA, SPI CLK
9	IOHR	P1[2]	Digital I/O
10	IOHR	P1[4]	Digital I/O, optional external clock input (EXTCLK)
11	Input	XRES	Active high external reset with internal pull-down
12	IOHR	P0[4]	Digital I/O
13	Power	Vdd	Power pin
14	IOHR	P0[7]	Digital I/O
15	IOHR	P0[3]	Digital I/O
16	IOHR	P0[1]	Digital I/O

LEGEND I = Input, O = Output, OH = 5 mA High Output Drive, R = Regulated Output.

Notes

1. During power up or reset event, device P1[0] and P1[1] may disturb the I2C bus. Use alternate pins if issues are encountered.
2. These are the ISSP pins, that are not High Z at POR.

32-Pin Part Pinout

Figure 6. CY7C60445 32-Pin enCoRe V LV Device

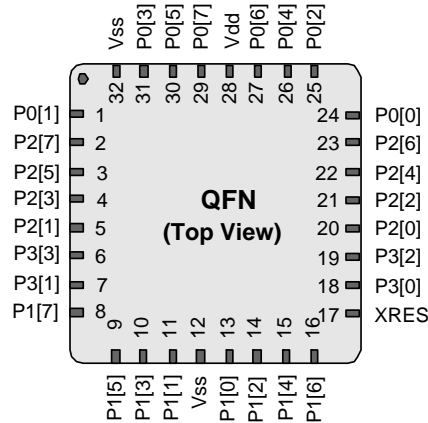

Table 2. 32-Pin Part Pinout (QFN)

Pin No.	Type	Name	Description
1	IOH	P0[1]	Digital I/O
2	I/O	P2[7]	Digital I/O
3	I/O	P2[5]	Digital I/O, crystal out (Xout)
4	I/O	P2[3]	Digital I/O, crystal in (Xin)
5	I/O	P2[1]	Digital I/O
6	I/O	P3[3]	Digital I/O
7	I/O	P3[1]	Digital I/O
8	IOHR	P1[7]	Digital I/O, I ² C SCL, SPI SS
9	IOHR	P1[5]	Digital I/O, I ² C SDA, SPI MISO
10	IOHR	P1[3]	Digital I/O, SPI CLK
11	IOHR	P1[1] ^(1,2)	Digital I/O, ISSP CLK, I ² C SCL, SPI MOSI
12	Power	Vss	Ground connection
13	IOHR	P1[0] ^(1,2)	Digital I/O, ISSP DATA, I ² C SDA, SPI CLK
14	IOHR	P1[2]	Digital I/O
15	IOHR	P1[4]	Digital I/O, optional external clock input (EXTCLK)
16	IOHR	P1[6]	Digital I/O
17	Reset Input	XRES	Active high external reset with internal pull-down
18	I/O	P3[0]	Digital I/O
19	I/O	P3[2]	Digital I/O
20	I/O	P2[0]	Digital I/O
21	I/O	P2[2]	Digital I/O
22	I/O	P2[4]	Digital I/O
23	I/O	P2[6]	Digital I/O
24	IOH	P0[0]	Digital I/O
25	IOH	P0[2]	Digital I/O
26	IOH	P0[4]	Digital I/O
27	IOH	P0[6]	Digital I/O

Table 2. 32-Pin Part Pinout (QFN) (continued)

Pin No.	Type	Name	Description
28	Power	Vdd	Supply voltage
29	IOH	P0[7]	Digital I/O
30	IOH	P0[5]	Digital I/O
31	IOH	P0[3]	Digital I/O
32	Power	Vss	Ground connection
CP	Power	Vss	Center pad must be connected to ground

LEGEND I = Input, O = Output, OH = 5 mA High Output Drive, R = Regulated Output.

48-Pin Part Pinout

Figure 7. CY7C60455/CY7C60456 48-Pin enCoRe V LV Device

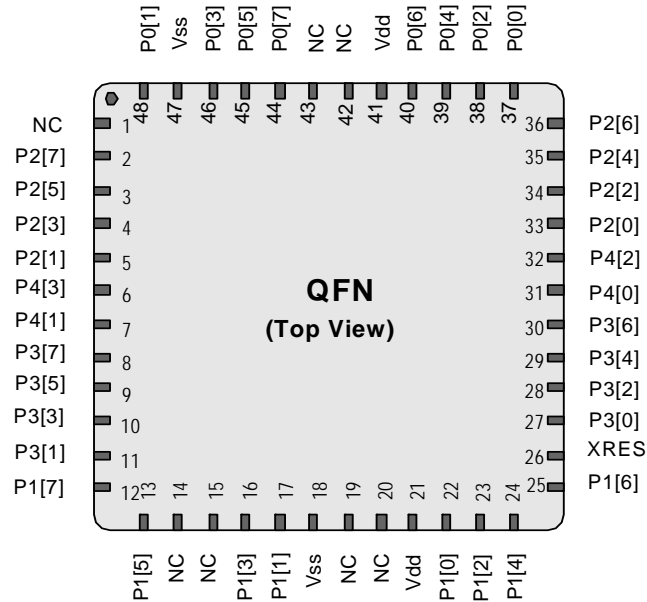

Table 3. 48-Pin Part Pinout (QFN)

Pin No.	Type	Name	Description
1	NC	NC	No connection
2	I/O	P2[7]	Digital I/O
3	I/O	P2[5]	Digital I/O, crystal out (Xout)
4	I/O	P2[3]	Digital I/O, crystal in (Xin)
5	I/O	P2[1]	Digital I/O
6	I/O	P4[3]	Digital I/O
7	I/O	P4[1]	Digital I/O
8	I/O	P3[7]	Digital I/O
9	I/O	P3[5]	Digital I/O
10	I/O	P3[3]	Digital I/O
11	I/O	P3[1]	Digital I/O
12	IOHR	P1[7]	Digital I/O, I ² C SCL, SPI SS
13	IOHR	P1[5]	Digital I/O, I ² C SDA, SPI MISO
14	NC	NC	No connection
15	NC	NC	No connection
16	IOHR	P1[3]	Digital I/O, SPI CLK
17	IOHR	P1[1] ^(1,2)	Digital I/O, ISSP CLK, I ² C SCL, SPI MOSI
18	Power	Vss	Supply ground
19	NC	NC	No connection
20	NC	NC	No connection
21	Power	Vdd	Supply voltage

Table 3. 48-Pin Part Pinout (QFN) (continued)

Pin No.	Type	Name	Description
22	IOHR	P1[0] ^(1,2)	Digital I/O, ISSP DATA, I2C SDA, SPI CLK
23	IOHR	P1[2]	Digital I/O
24	IOHR	P1[4]	Digital I/O, optional external clock input (EXTCLK)
25	IOHR	P1[6]	Digital I/O
26	XRES	Ext Reset	Active high external reset with internal pull-down
27	I/O	P3[0]	Digital I/O
28	I/O	P3[2]	Digital I/O
29	I/O	P3[4]	Digital I/O
30	I/O	P3[6]	Digital I/O
31	I/O	P4[0]	Digital I/O
32	I/O	P4[2]	Digital I/O
33	I/O	P2[0]	Digital I/O
34	I/O	P2[2]	Digital I/O
35	I/O	P2[4]	Digital I/O
36	I/O	P2[6]	Digital I/O
37	IOH	P0[0]	Digital I/O
38	IOH	P0[2]	Digital I/O
39	IOH	P0[4]	Digital I/O
40	IOH	P0[6]	Digital I/O
41	Power	Vdd	Supply voltage
42	NC	NC	No connection
43	NC	NC	No connection
44	IOH	P0[7]	Digital I/O
45	IOH	P0[5]	Digital I/O
46	IOH	P0[3]	Digital I/O
47	Power	Vss	Supply ground
48	IOH	P0[1]	Digital I/O
CP	Power	Vss	Center pad must be connected to ground

LEGEND I = Input, O = Output, OH = 5 mA High Output Drive, R = Regulated Output

Register Reference

The section discusses the registers of the enCoRe V LV device. It lists all the registers in mapping tables, in address order.

Register Conventions

The register conventions specific to this section are listed in the following table.

Table 4. Register Conventions

Convention	Description
R	Read register or bits
W	Write register or bits
L	Logical register or bits
C	Clearable register or bits
#	Access is bit specific

Register Mapping Tables

The enCoRe V LV device has a total register address space of 512 bytes. The register space is also referred to as I/O space and is broken into two parts: Bank 0 (user space) and Bank 1 (configuration space). The XIO bit in the Flag register (CPU_F) determines which bank the user is currently in. When the XIO bit is set, the user is said to be in the 'extended' address space or the 'configuration' registers.

Table 5. Register Map Bank 0 Table: User Space

Name	Addr (0,Hex)	Access	Name	Addr (0,Hex)	Access	Name	Addr (0,Hex)	Access	Name	Addr (0,Hex)	Access
PRT0DR	00	RW		40			80			C0	
PRT0IE	01	RW		41			81			C1	
	02			42			82			C2	
	03			43			83			C3	
PRT1DR	04	RW		44			84			C4	
PRT1IE	05	RW		45			85			C5	
	06			46			86			C6	
	07			47			87			C7	
PRT2DR	08	RW		48			88		I2C_XCFG	C8	RW
PRT2IE	09	RW		49			89		I2C_XSTAT	C9	R
	0A			4A			8A		I2C_ADDR	CA	RW
	0B			4B			8B		I2C_BP	CB	R
PRT3DR	0C	RW		4C			8C		I2C_CP	CC	R
PRT3IE	0D	RW		4D			8D		CPU_BP	CD	RW
	0E			4E			8E		CPU_CP	CE	R
	0F			4F			8F		I2C_BUF	CF	RW
PRT4DR	10	RW		50			90		CUR_PP	D0	RW
PRT4IE	11	RW		51			91		STK_PP	D1	RW
	12			52			92			D2	
	13			53			93		IDX_PP	D3	RW
	14			54			94		MVR_PP	D4	RW
	15			55			95		MVW_PP	D5	RW
	16			56			96		I2C_CFG	D6	RW
	17			57			97		I2C_SCR	D7	#
	18			58			98		I2C_DR	D8	RW
	19			59			99			D9	
	1A			5A			9A		INT_CLR0	DA	RW
	1B			5B			9B		INT_CLR1	DB	RW
	1C			5C			9C		INT_CLR2	DC	RW
	1D			5D			9D		INT_CLR3	DD	RW
	1E			5E			9E		INT_MSK2	DE	RW
	1F			5F			9F		INT_MSK1	DF	RW
	20			60			A0		INT_MSK0	E0	RW
	21			61			A1		INT_SW_EN	E1	RW
	22			62			A2		INT_VC	E2	RC
	23			63			A3		RES_WDT	E3	W
	24			64			A4		INT_MSK3	E4	RW
	25			65			A5			E5	
	26			66			A6			E6	
	27			67			A7			E7	
	28			68			A8			E8	
SPI_TXR	29	W		69			A9			E9	
SPI_RXR	2A	R		6A			AA			EA	
SPI_CR	2B	#		6B			AB			EB	
	2C			6C			AC			EC	
	2D			6D			AD			ED	
	2E			6E			AE			EE	
	2F			6F			AF			EF	
	30			70		PT0_CFG	B0	RW		F0	
	31			71		PT0_DATA1	B1	RW		F1	
	32			72		PT0_DATA0	B2	RW		F2	
	33			73		PT1_CFG	B3	RW		F3	
	34			74		PT1_DATA1	B4	RW		F4	
	35			75		PT1_DATA0	B5	RW		F5	
	36			76		PT2_CFG	B6	RW		F6	
	37			77		PT2_DATA1	B7	RW	CPU_F	F7	RL
	38			78		PT2_DATA0	B8	RW		F8	
	39			79			B9			F9	
	3A			7A			BA			FA	
	3B			7B			BB			FB	
	3C			7C			BC			FC	
	3D			7D			BD			FD	
	3E			7E			BE		CPU_SCR1	FE	#
	3F			7F			BF		CPU_SCR0	FF	#

Gray fields are reserved and should not be accessed. # Access is bit specific.

Table 6. Register Map Bank 1 Table: Configuration Space

Name	Addr (1,Hex)	Access	Name	Addr (1,Hex)	Access	Name	Addr (1,Hex)	Access	Name	Addr (1,Hex)	Access
PRT0DM0	00	RW		40			80			C0	
PRT0DM1	01	RW		41			81			C1	
	02			42			82			C2	
	03			43			83			C3	
PRT1DM0	04	RW		44			84			C4	
PRT1DM1	05	RW		45			85			C5	
	06			46			86			C6	
	07			47			87			C7	
PRT2DM0	08	RW		48			88			C8	
PRT2DM1	09	RW		49			89			C9	
	0A			4A			8A			CA	
	0B			4B			8B			CB	
PRT3DM0	0C	RW		4C			8C			CC	
PRT3DM1	0D	RW		4D			8D			CD	
	0E			4E			8E			CE	
	0F			4F			8F			CF	
PRT4DM0	10	RW		50			90			D0	
PRT4DM1	11	RW		51			91			D1	
	12			52			92			D2	
	13			53			93			D3	
	14			54			94			D4	
	15			55			95			D5	
	16			56			96			D6	
	17			57			97			D7	
	18			58			98			D8	
	19			59			99			D9	
	1A			5A			9A			DA	
	1B			5B			9B			DB	
	1C			5C			9C		IO_CFG	DC	RW
	1D			5D			9D		OUT_P1	DD	RW
	1E			5E			9E			DE	
	1F			5F			9F			DF	
	20			60			A0		OSC_CR0	E0	RW
	21			61			A1		ECO_CFG	E1	#
	22			62			A2		OSC_CR2	E2	RW
	23			63			A3		VLT_CR	E3	RW
	24			64			A4		VLT_CMP	E4	R
	25			65			A5			E5	
	26			66			A6			E6	
	27			67			A7			E7	
	28			68			A8		IMO_TR	E8	W
SPI_CFG	29	RW		69			A9		ILO_TR	E9	W
	2A			6A			AA			EA	
	2B			6B			AB		SLP_CFG	EB	RW
	2C		TMP_DR0	6C	RW		AC		SLP_CFG2	EC	RW
	2D		TMP_DR1	6D	RW		AD		SLP_CFG3	ED	RW
	2E		TMP_DR2	6E	RW		AE			EE	
	2F		TMP_DR3	6F	RW		AF			EF	
	30			70			B0			F0	
	31			71			B1			F1	
	32			72			B2			F2	
	33			73			B3			F3	
	34			74			B4			F4	
	35			75			B5			F5	
	36			76			B6			F6	
	37			77			B7		CPU_F	F7	RL
	38			78			B8			F8	
	39			79			B9			F9	
	3A			7A			BA			FA	
	3B			7B			BB			FB	
	3C			7C			BC			FC	
	3D			7D			BD			FD	
	3E			7E			BE			FE	
	3F			7F			BF			FF	

Gray fields are reserved and should not be accessed. # Access is bit specific.

Electrical Specifications

This section presents the DC and AC electrical specifications of the enCoRe V LV devices. For the most up to date electrical specifications, verify that you have the most recent datasheet available by visiting the company web site at <http://www.cypress.com>.

Figure 8. Voltage versus CPU Frequency

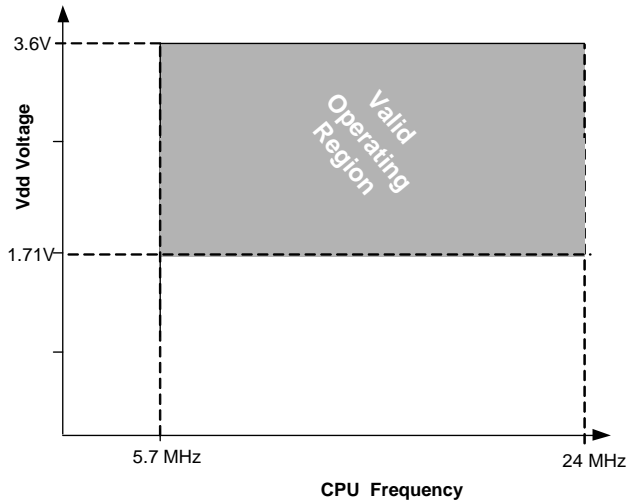
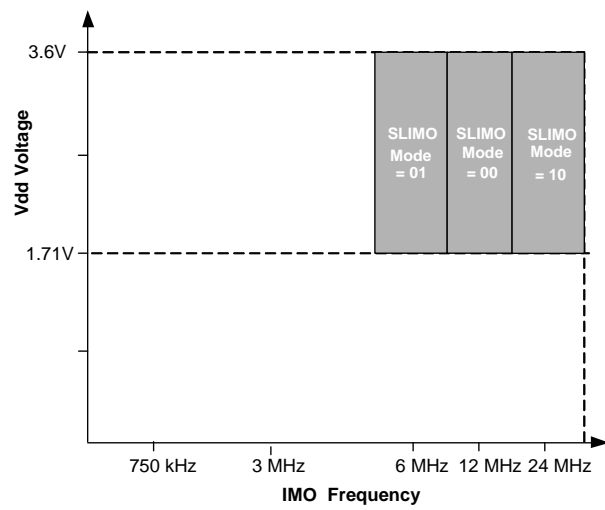

Figure 9. IMO Frequency Trim Options



Absolute Maximum Ratings

Exceeding maximum ratings may shorten the useful life of the device. User guidelines are not tested.

Table 7. Absolute Maximum Ratings

Symbol	Description	Conditions	Min	Typ	Max	Units
T _{STG}	Storage temperature ^[3]	Higher storage temperatures reduces data retention time. Recommended storage temperature is +25 °C ± 25 °C. Extended duration storage temperatures above 85 °C degrades reliability.	-55	+25	+125	°C
V _{dd}	Supply voltage relative to V _{ss}		-0.5	-	+6.0	V
V _{IO}	DC input voltage		V _{ss} - 0.5	-	V _{dd} + 0.5	V
V _{IOZ}	DC voltage applied to tristate		V _{ss} - 0.5	-	V _{dd} + 0.5	V
I _{MIO}	Maximum current into any Port pin		-25	-	+50	mA
ESD	Electro static discharge voltage	Human body model ESD	2000	-	-	V
LU	Latch up current	In accordance with JESD78 standard	-	-	200	mA

Operating Temperature

Table 8. Operating Temperature

Symbol	Description	Conditions	Min	Typ	Max	Units
T _{AC}	Ambient commercial temperature		0		+70	°C
T _{JC}	Operational commercial die temperature ^[4]	The temperature rise from ambient to junction is package specific. Refer the table " Thermal Impedances " on page 30. The user must limit the power consumption to comply with this requirement.	0		+85	°C

Notes

- Higher storage temperatures reduce data retention time. Recommended storage temperature is +25 °C ± 25 °C. Extended duration storage temperatures above 85 °C degrade reliability.
- The temperature rise from ambient to junction is package specific. See [Thermal Impedances on page 30](#). The user must limit the power consumption to comply with this requirement.

DC Electrical Characteristics

DC Chip Level Specifications

Table 9 lists guaranteed maximum and minimum specifications for the entire voltage and temperature ranges.

Table 9. DC Chip Level Specifications

Symbol	Description	Conditions	Min	Typ	Max	Units
V _{dd} ^[5, 6]	Supply voltage	See table titled DC POR and LVD Specifications on page 22 .	1.71	–	3.6	V
I _{DD24}	Supply current, IMO = 24 MHz	Conditions are V _{dd} ≤ 3.0 V, T _A = 25 °C, CPU = 24 MHz No I2C/SPI	–	2.9	4.0	mA
I _{DD12}	Supply current, IMO = 12 MHz	Conditions are V _{dd} ≤ 3.0 V, T _A = 25 °C, CPU = 12 MHz No I2C/SPI	–	1.7	2.6	mA
I _{DD6}	Supply current, IMO = 6 MHz	Conditions are V _{dd} ≤ 3.0 V, T _A = 25 °C, CPU = 6 MHz No I2C/SPI	–	1.2	1.8	mA
I _{SB1}	Standby current with POR, LVD, and Sleep timer	V _{dd} ≤ 3.0V, T _A = 25 °C, I/O regulator turned off	–	1.1	1.5	μA
I _{SB0}	Deep sleep current	V _{dd} ≤ 3.0 V, T _A = 25 °C, I/O regulator turned off	–	0.1	–	μA

Notes

5. When V_{dd} remains in the range from 1.71 V to 1.9 V for more than 50 μsec, the slew rate when moving from the 1.71 V to 1.9 V range to greater than 2 V must be slower than 1 V/500 μsec to avoid triggering POR. The only other restriction on slew rates for any other voltage range or transition is the SR_{POWER_UP} parameter.
6. If powering down in standby sleep mode, to properly detect and recover from a VDD brown out condition any of the following actions must be taken:
 - Bring the device out of sleep before powering down.
 - Assure that VDD falls below 100 mV before powering backup.
 - Set the No Buzz bit in the OSC_CR0 register to keep the voltage monitoring circuit powered during sleep.
 - Increase the buzz rate to assure that the falling edge of VDD is captured. The rate is configured through the PSSDC bits in the SLP_CFG register.
 For the referenced registers, refer to the enCoRe V Technical Reference Manual. In deep sleep mode, additional low power voltage monitoring circuitry allows VDD brown out conditions to be detected for edge rates slower than 1 V/ms.

DC General Purpose I/O Specifications ^[7]

The following tables list guaranteed maximum and minimum specifications for the voltage and temperature ranges: 1.71 V to 3.6 V and $0\text{ }^{\circ}\text{C} \leq T_A \leq 70\text{ }^{\circ}\text{C}$. Typical parameters apply to 3.3 V at 25 °C. These are for design guidance only.

Table 10. 3.0 V to 3.6 V DC GPIO Specifications

Symbol	Description	Conditions	Min	Typ	Max	Units
R _{PU}	Pull-up resistor	–	4	5.6	8	kΩ
V _{OH1}	High output voltage Port 2 or 3 pins	I _{OH} ≤ 10 μA, maximum of 10 mA source current in all I/Os	V _{dd} – 0.2	–	–	V
V _{OH2}	High output voltage Port 2 or 3 pins	I _{OH} = 1 mA, maximum of 20 mA source current in all I/Os	V _{dd} – 0.9	–	–	V
V _{OH3}	High output voltage Port 0 or 1 pins with LDO regulator disabled for Port 1	I _{OH} < 10 μA, maximum of 10 mA source current in all I/Os	V _{dd} – 0.2	–	–	V
V _{OH4}	High output voltage Port 0 or 1 pins with LDO regulator disabled for Port 1	I _{OH} = 5 mA, maximum of 20 mA source current in all I/Os	V _{dd} – 0.9	–	–	V
V _{OH5}	High output voltage Port 1 pins with LDO regulator enabled for 3 V out	I _{OH} < 10 μA, V _{dd} > 3.1 V, maximum of 4 I/Os all sourcing 5 mA	2.85	3.00	3.3	V
V _{OH6}	High output voltage Port 1 pins with LDO regulator enabled for 3 V out	I _{OH} = 5 mA, V _{dd} > 3.1 V, maximum of 20 mA source current in all I/Os	2.20	–	–	V
V _{OH7}	High output voltage Port 1 pins with LDO enabled for 2.5 V out	I _{OH} < 10 μA, V _{dd} > 2.7 V, maximum of 20 mA source current in all I/Os	2.35	2.50	2.75	V
V _{OH8}	High output voltage Port 1 pins with LDO enabled for 2.5 V out	I _{OH} = 2 mA, V _{dd} > 2.7 V, maximum of 20 mA source current in all I/Os	1.90	–	–	V
V _{OH9}	High output voltage Port 1 pins with LDO enabled for 1.8 V out	I _{OH} < 10 μA, V _{dd} > 2.7 V, maximum of 20 mA source current in all I/Os	1.60	1.80	2.1	V
V _{OH10}	High output voltage Port 1 pins with LDO enabled for 1.8 V out	I _{OH} = 1 mA, V _{dd} > 2.7 V, maximum of 20 mA source current in all I/Os	1.20	–	–	V
V _{OL}	Low output voltage	I _{OL} = 25 mA, V _{dd} > 3.3 V, maximum of 60 mA sink current on even port pins (for example, P0[2] and P1[4]) and 60 mA sink current on odd port pins (for example, P0[3] and P1[5])	–	–	0.75	V
V _{IL}	Input low voltage	–	–	–	0.80	V
V _{IH}	Input high voltage	–	2.00	–	–	V
V _H	Input hysteresis voltage	–	–	80	–	mV
I _{IL}	Input leakage (absolute value)	–	–	0.001	1	μA
C _{PIN}	Pin capacitance	Package and pin dependent Temp = 25 °C	0.5	1.7	5	pF

Note

7. **Errata:** P1[3], P1[6], and P1[7] pins are susceptible to latch up when the I/O sink current exceeds 25 mA per pin on these pins. Add a series resistor > 300 Ω to P1[3], P1[6], and P1[7] pins to restrict current to within latch up limits. For more information please refer to "Errata" on page 33.

Table 11. 2.4 V to 3.0 V DC GPIO Specifications

Symbol	Description	Conditions	Min	Typ	Max	Units
R _{PU}	Pull-up resistor	–	4	5.6	8	kΩ
V _{OH1}	High output voltage Port 2 or 3 pins	I _{OH} < 10 μA, maximum of 10 mA source current in all I/Os	V _{dd} – 0.2	–	–	V
V _{OH2}	High output voltage Port 2 or 3 pins	I _{OH} = 0.2 mA, maximum of 10 mA source current in all I/Os	V _{dd} – 0.4	–	–	V
V _{OH3}	High output voltage Port 0 or 1 pins with LDO regulator disabled for Port 1	I _{OH} < 10 μA, maximum of 10 mA source current in all I/Os	V _{dd} – 0.2	–	–	V
V _{OH4}	High output voltage Port 0 or 1 pins with LDO regulator disabled for Port 1	I _{OH} = 2 mA, maximum of 10 mA source current in all I/Os	V _{dd} – 0.5	–	–	V
V _{OH5A}	High output voltage Port 1 pins with LDO enabled for 1.8 V out	I _{OH} < 10 μA, V _{dd} > 2.4V, maximum of 20 mA source current in all I/Os.	1.50	1.80	2.10	V
V _{OH6A}	High output voltage Port 1 pins with LDO enabled for 1.8 V out	I _{OH} = 1 mA, V _{dd} > 2.4V, maximum of 20 mA source current in all I/Os	1.20	–	–	V
V _{OL}	Low output voltage	I _{OL} = 10 mA, maximum of 30 mA sink current on even port pins (for example, P0[2] and P1[4]) and 30 mA sink current on odd port pins (for example, P0[3] and P1[5])	–	–	0.75	V
V _{IL}	Input low voltage	–	–	–	0.72	V
V _{IH}	Input high voltage	–	1.4	–	–	V
V _H	Input hysteresis voltage	–	–	80	–	mV
I _{IL}	Input leakage (absolute value)	–	–	0.001	1	μA
C _{PIN}	Capacitive load on pins	Package and pin dependent Temp = 25 °C	0.5	1.7	5	pF

Table 12. 1.71 V to 2.4 V DC GPIO Specifications

Symbol	Description	Conditions	Min	Typ	Max	Units
R _{PU}	Pull-up resistor	–	4	5.6	8	kΩ
V _{OH1}	High output voltage Port 2 or 3 pins	I _{OH} = 10 μA, maximum of 10 mA source current in all I/Os	V _{dd} – 0.2	–	–	V
V _{OH2}	High output voltage Port 2 or 3 pins	I _{OH} = 0.5 mA, maximum of 10 mA source current in all I/Os	V _{dd} – 0.5	–	–	V
V _{OH3}	High output voltage Port 0 or 1 pins with LDO regulator disabled for Port 1	I _{OH} = 100 μA, maximum of 10 mA source current in all I/Os	V _{dd} – 0.2	–	–	V
V _{OH4}	High output voltage Port 0 or 1 pins with LDO regulator disabled for Port 1	I _{OH} = 2 mA, maximum of 10 mA source current in all I/Os	V _{dd} – 0.5	–	–	V
V _{OL}	Low output voltage	I _{OL} = 5 mA, maximum of 20 mA sink current on even port pins (for example, P0[2] and P1[4]) and 30 mA sink current on odd port pins (for example, P0[3] and P1[5])	–	–	0.4	V
V _{IL}	Input low voltage	–	–	–	0.3 x V _{dd}	V
V _{IH}	Input high voltage	–	0.65 x V _{dd}	–	–	V
V _H	Input hysteresis voltage	–	–	80	–	mV
I _{IL}	Input leakage (absolute value)	–	–	0.001	1	μA
C _{PIN}	Capacitive load on pins	Package and pin dependent. Temp = 25 °C	0.5	1.7	5	pF

ADC Electrical Specifications
Table 13. ADC User Module Electrical Specifications

Symbol	Description	Conditions	Min	Typ	Max	Units
Input						
V _{IN}	Input voltage range	–	0	–	V _{REFADC}	V
C _{IIN}	Input capacitance	–		–	5	pF
R _{IN}	Input resistance	Equivalent switched cap input resistance for 8-, 9-, or 10-bit resolution	1/(500fF × data clock)	1/(400fF × data clock)	1/(300fF × data clock)	Ω
Reference						
V _{REFADC}	ADC reference voltage	–	1.14	–	1.26	V
Conversion Rate						
F _{CLK}	Data clock	Source is chip's internal main oscillator. See AC Chip-Level Specifications for accuracy	2.25	–	6	MHz
S ₈	8-bit sample rate	Data Clock set to 6 MHz. Sample Rate = 0.001/ (2 ^{Resolution} /Data Clock)	–	–	–	ksps
S ₁₀	10-bit sample rate	Data Clock set to 6 MHz. Sample Rate = 0.001/ (2 ^{Resolution} /Data Clock)	–	5.859	–	ksps
DC Accuracy						
RES	Resolution	Can be set to 8-, 9-, or 10-bit	8	–	10	bits
DNL	Differential nonlinearity	–	–1	–	+2	LSB
INL	Integral nonlinearity	–	–2	–	+2	LSB
E _{Offset}	Offset error	8-bit resolution	0	3.2	19.2	LSB
		10-bit resolution	0	12.8	76.8	LSB
E _{gain}	Gain error	For any resolution	–5	–	+5	%FSR
Power						
I _{ADC}	Operating current	–	–	2.1	2.6	mA
PSRR	Power supply rejection ratio	PSRR (V _{dd} > 3.0 V)	–	24	–	dB
		PSRR (V _{dd} < 3.0 V)	–	30	–	dB

DC POR and LVD Specifications

Table 14 lists guaranteed maximum and minimum specifications for the entire voltage and temperature ranges.

Table 14. DC POR and LVD Specifications

Symbol	Description	Min	Typ	Max	Units
	Vdd Value for PPOR Trip ⁽⁸⁾				
V _{PPOR0}	PORLEV[1:0] = 00b, HPOR = 0	1.61	1.66	1.71	V
V _{PPOR1}	PORLEV[1:0] = 00b, HPOR = 1		2.36	2.41	V
V _{PPOR2}	PORLEV[1:0] = 01b, HPOR = 1		2.60	2.66	V
V _{PPOR3}	PORLEV[1:0] = 10b, HPOR = 1		2.82	2.95	V
	Vdd Value for LVD Trip				
V _{LVD0}	VM[2:0] = 000b ⁽⁹⁾	2.40	2.45	2.51	V
V _{LVD1}	VM[2:0] = 001b ⁽¹⁰⁾	2.64	2.71	2.78	V
V _{LVD2}	VM[2:0] = 010b ⁽¹¹⁾	2.85	2.92	2.99	V
V _{LVD3}	VM[2:0] = 011b	2.95	3.02	3.09	V
V _{LVD4}	VM[2:0] = 100b	3.06	3.13	3.20	V
V _{LVD5}	VM[2:0] = 101b	1.84	1.9	2.32	V
V _{LVD6}	VM[2:0] = 110b ⁽¹²⁾	1.75	1.8	1.84	V

DC Programming Specifications

Table 15 lists guaranteed maximum and minimum specifications for the entire voltage and temperature ranges.

Table 15. DC Programming Specifications

Symbol	Description	Min	Typ	Max	Units
V _{ddIWRITE}	Supply voltage for flash write operations	1.71	–	5.25	V
I _{DDP}	Supply current during programming or verify	–	5	25	mA
V _{ILP}	Input low voltage during programming or verify	–	–	V _{IL} ^[11]	V
V _{IHP}	Input high voltage during programming or verify	1.71	–	V _{ddIWRITE} + 0.3	V
I _{ILP}	Input current when applying V _{ilp} to P1[0] or P1[1] during programming or verify ⁽¹³⁾	–	–	0.2	mA
I _{IHP}	Input current when applying V _{ihp} to P1[0] or P1[1] during programming or verify ⁽¹³⁾	–	–	1.5	mA
V _{OLP}	Output low voltage during programming or verify	–	–	V _{ss} + 0.75	V
V _{OHP}	Output high voltage during programming or verify	V _{ddIWRITE} - 0.9 V	–	V _{ddIWRITE}	V
Flash _{ENPB}	Flash write endurance ⁽¹⁵⁾	50,000	–	–	Cycles
Flash _{DR}	Flash data retention ⁽¹⁶⁾	10	20	–	Years

Notes

8. V_{dd} must be greater than or equal to 1.71 V during startup, reset from the XRES pin, or reset from watchdog.
9. Always greater than 50 mV above V_{PPOR1} for falling supply.
10. Always greater than 50 mV above V_{PPOR2} for falling supply.
11. Always greater than 50 mV above V_{PPOR3} for falling supply.
12. Always greater than 50 mV above V_{PPOR0} voltage for falling supply.
13. Driving internal pull-down resistor.
14. See appropriate [DC General Purpose I/O Specifications \[7\]](#) table.
15. Erase/write cycles per block.
16. Following maximum Flash write cycles at T_{amb} = 55C and T_j = 70C.

AC Electrical Characteristics

AC Chip Level Specifications

Table 16 lists guaranteed maximum and minimum specifications for the entire voltage and temperature ranges.

Table 16. AC Chip Level Specifications

Symbol	Description	Conditions	Min	Typ	Max	Units
F _{CPU}	Processing frequency		5.7	–	25.2	MHz
F _{32K1}	Internal low speed oscillator frequency	Trimmed for 3.3 V operation using factory trim values	19	32	50	kHz
F _{32K_U}	Internal low speed oscillator (ILO) untrimmed frequency	–	13	32	82	kHz
F _{32K2}	Internal low speed oscillator frequency	Untrimmed	13	32	82	kHz
F _{IMO24}	Internal main oscillator stability for 24 MHz ± 5%	–	22.8	24	25.2	MHz
F _{IMO12}	Internal main oscillator stability for 12 MHz	–	11.4	12	12.6	MHz
F _{IMO6}	Internal main oscillator stability for 6 MHz	–	5.7	6.0	6.3	MHz
DC _{IMO}	Duty Cycle of IMO	–	40	50	60	%
DC _{ILO}	Internal low speed oscillator duty cycle	–	40	50	60	%
SR _{POWER_UP}	Power supply slew rate	–	–	–	250	V/ms
T _{XRST}	External reset pulse width at power up	After supply voltage is valid	1	–	–	ms
T _{XRST2}	External reset pulse width after power up ^[17]	Applies after part has booted	10	–	–	μs

Note

17. The minimum required XRES pulse length is longer when programming the device (see Table 19 on page 25).

AC General Purpose IO Specifications

Table 17 lists guaranteed maximum and minimum specifications for the entire voltage and temperature ranges.

Table 17. AC GPIO Specifications

Symbol	Description	Conditions	Min	Typ	Max	Units
F _{GPIO}	GPIO operating frequency	Normal strong mode, port 0, 1	0	–	6 MHz for 1.71 V < V _{dd} < 2.4 V	MHz
			0	–	12 MHz for 2.4 V < V _{dd} < 3.6 V	
		Normal strong mode, Port 2, 3	0	–	3 MHz for 1.71 V < V _{dd} < 2.4 V	MHz
					6 MHz for 3.0 V < V _{dd} < 3.6 V	
TRise23	Rise time, strong mode, load = 50 pF Ports 2 or 3	V _{dd} = 3.0 to 3.6 V, 10% – 90%	15	–	80	ns
TRise23L	Rise time, strong mode low supply, load = 50 pF Ports 2 or 3	V _{dd} = 1.71 to 3.0 V, 10% – 90%	15	–	80	ns
TRise01	Rise time, strong mode, load = 50 pF Ports 0 or 1	V _{dd} = 3.0 to 3.6 V, 10% – 90% LDO enabled or disabled	10	–	50	ns
TRise01L	Rise time, strong mode low supply, load = 50 pF Ports 0 or 1	V _{dd} = 1.71 to 3.0 V, 10% – 90% LDO enabled or disabled	15	–	80	ns
TFall	Fall time, strong mode, load = 50 pF, All Ports	V _{dd} = 3.0 to 3.6 V, 10% – 90%	10	–	50	ns
TFallL	Fall time, strong mode low supply, load = 50 pF, all ports	V _{dd} = 1.71 to 3.0 V, 10% - 90%	10	–	70	ns

Figure 10. GPIO Timing Diagram

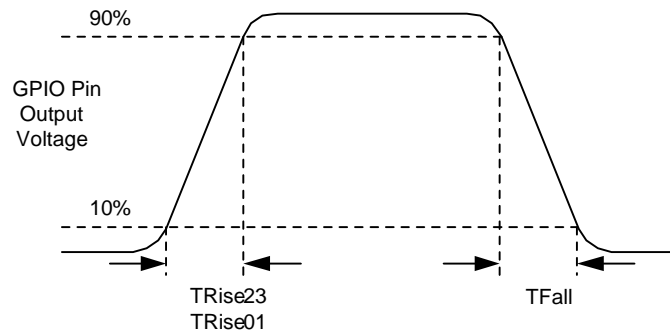

AC External Clock Specifications

Table 18 lists guaranteed maximum and minimum specifications for the entire voltage and temperature ranges.

Table 18. AC External Clock Specifications

Symbol	Description	Conditions	Min	Typ	Max	Units
F _{OSCEXT}	Frequency	–	0.750	–	25.2	MHz
–	High period	–	20.6	–	5300	ns
–	Low period	–	20.6	–	–	ns
–	Power up IMO to switch	–	150	–	–	μs

AC Programming Specifications

Table 19 lists guaranteed maximum and minimum specifications for the entire voltage and temperature ranges.

Table 19. AC Programming Specifications

Symbol	Description	Conditions	Min	Typ	Max	Units
T _{RSCLK}	Rise time of SCLK	–	1	–	20	ns
T _{FSCLK}	Fall time of SCLK	–	1	–	20	ns
T _{SSCLK}	Data set up time to falling edge of SCLK	–	40	–	–	ns
T _{HSCLK}	Data hold time from falling edge of SCLK	–	40	–	–	ns
F _{SCLK}	Frequency of SCLK	–	0	–	8	MHz
T _{ERASEB}	Flash erase time (block)	–	–	–	18	ms
T _{WRITE}	Flash block write time	–	–	–	25	ms
T _{DSCLK1}	Data out delay from falling edge of SCLK	3.0 V < V _{dd} < 3.6 V	–	–	85	ns
T _{DSCLK2}	Data out delay from falling edge of SCLK	1.71 V < V _{dd} < 3.0 V	–	–	130	ns
T _{XRST3}	External reset pulse width after power up	Required to enter programming mode when coming out of sleep	263	–	–	μs

Figure 11. Timing Diagram - AC Programming Cycle

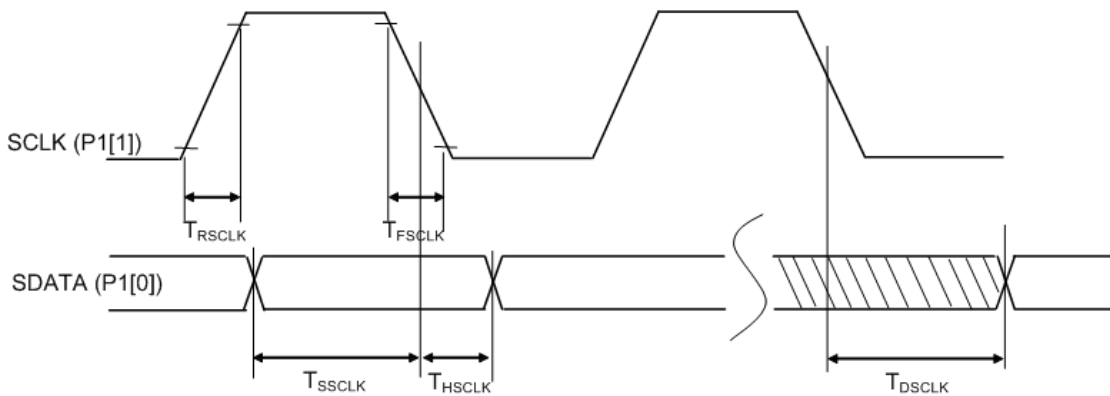

AC I²C Specifications

Table 20 lists guaranteed maximum and minimum specifications for the entire voltage and temperature ranges.

Table 20. AC Characteristics of the I²C SDA and SCL Pins

Symbol	Description	Standard Mode		Fast Mode		Units
		Min	Max	Min	Max	
F _{SCL I2C}	SCL clock frequency	0	100	0	400	kHz
T _{HDSTAI2C}	Hold time (repeated) START condition. After this period, the first clock pulse is generated.	4.0	–	0.6	–	μs
T _{LOWI2C}	LOW period of the SCL clock	4.7	–	1.3	–	μs
T _{HIGHI2C}	HIGH period of the SCL clock	4.0	–	0.6	–	μs
T _{SUSTAI2C}	Setup Time for a Repeated START condition	4.7	–	0.6	–	μs
T _{HDDATI2C}	Data hold time	0	–	0	–	μs
T _{SUDATI2C}	Data setup time	250	–	100 ⁽¹⁸⁾	–	ns
T _{SUSTOI2C}	Setup time for STOP condition	4.0	–	0.6	–	μs
T _{BUF I2C}	Bus free time between a STOP and START condition	4.7	–	1.3	–	μs
T _{SPI2C}	Pulse width of spikes are suppressed by the input filter	–	–	0	50	ns

Figure 12. Definition of Timing for Fast/Standard Mode on the I²C Bus

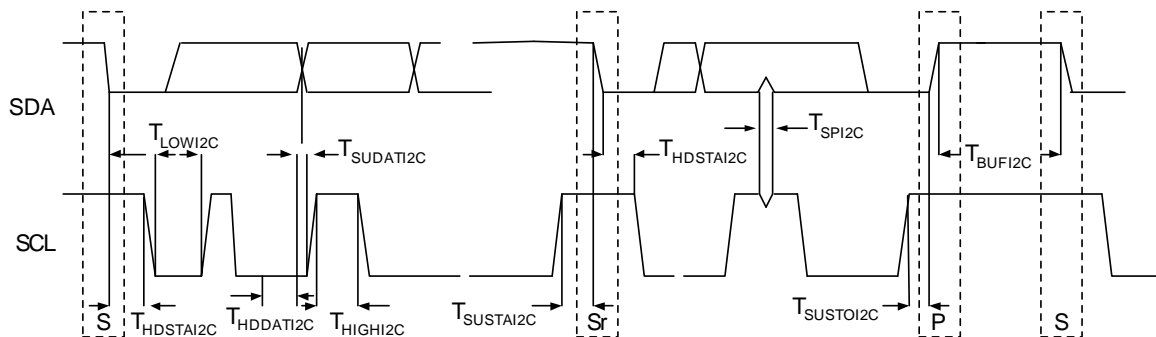

Note

18. A fast mode I2C bus device can be used in a standard mode I2C bus system, but the requirement t_{SU, DAT} ≥ 250 ns must then be met. This is automatically the case if the device does not stretch the LOW period of the SCL signal. If such device does stretch the LOW period of the SCL signal, it must output the next data bit to the SDA line t_{rmax} + t_{SU, DAT} = 1000 + 250 = 1250 ns (according to the standard mode I2C bus specification) before the SCL line is released.

Table 21. SPI Master AC Specifications

Symbol	Description	Conditions	Min	Typ	Max	Units
F _{SCLK}	SCLK clock frequency	V _{DD} ≥ 2.4 V V _{DD} < 2.4 V	–	–	6 3	MHz
DC	SCLK duty cycle	–	–	50	–	%
T _{SETUP}	MISO to SCLK setup time	V _{DD} ≥ 2.4 V V _{DD} < 2.4 V	60 100	–	–	ns
T _{HOLD}	SCLK to MISO hold time	–	40	–	–	ns
T _{OUT_VAL}	SCLK to MOSI valid time	–	–	–	40	ns
T _{OUT_HIGH}	MOSI high time	–	40	–	–	ns

Table 22. SPI Slave AC Specifications

Symbol	Description	Conditions	Min	Typ	Max	Units
F _{SCLK}	SCLK clock frequency	V _{DD} ≥ 2.4 V V _{DD} < 2.4 V	–	–	12 6	MHz
T _{LOW}	SCLK low time	–	41.67	–	–	ns
T _{HIGH}	SCLK high time	–	41.67	–	–	ns
T _{SETUP}	MOSI to SCLK setup time	–	30	–	–	ns
T _{HOLD}	SCLK to MOSI hold time	–	50	–	–	ns
T _{SS_MISO}	SS high to MISO valid	–	–	–	153	ns
T _{SCLK_MISO}	SCLK to MISO valid	–	–	–	125	ns
T _{SS_HIGH}	SS high time	–	–	–	50	ns
T _{SS_CLK}	Time from SS low to first SCLK	–	2/SCLK	–	–	ns
T _{CLK_SS}	Time from last SCLK to SS high	–	2/SCLK	–	–	ns

Package Diagram

This section illustrates the packaging specifications for the enCoRe V LV device, along with the thermal impedances for each package.

Important Note Emulation tools may require a larger area on the target PCB than the chip's footprint. For a detailed description of the enCoRe V LV emulation tools and their dimensions, refer to the development kit.

Packaging Dimensions

Figure 13. 16-pin Chip-On-Lead (3 × 3 × 0.6 mm) LG16A/LD16A (Sawn) Package Outline, 001-09116

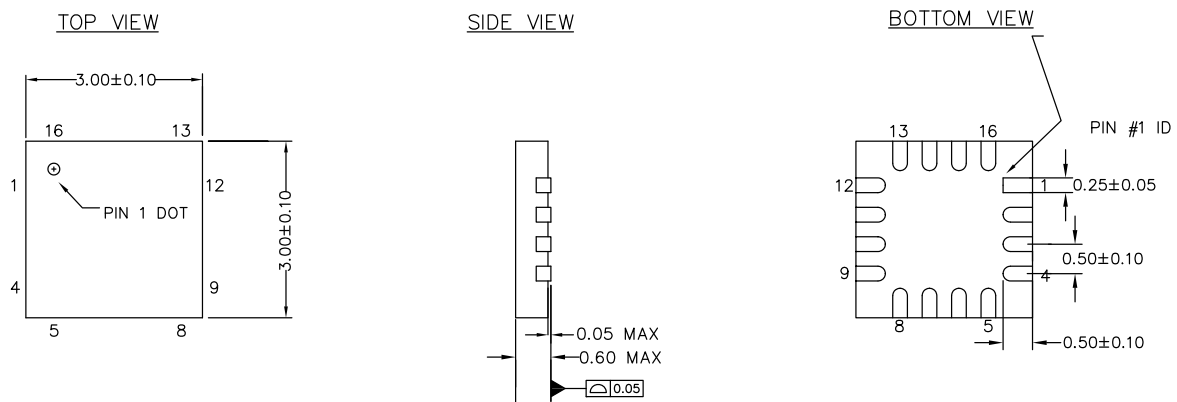

NOTES

1. REFERENCE JEDEC # MO-220
2. ALL DIMENSIONS ARE IN MILLIMETERS

001-09116 *1

Figure 14. 32-pin QFN (5 × 5 × 0.55 mm) LQ32 3.5 × 3.5 E-Pad (Sawn) Package Outline, 001-42168

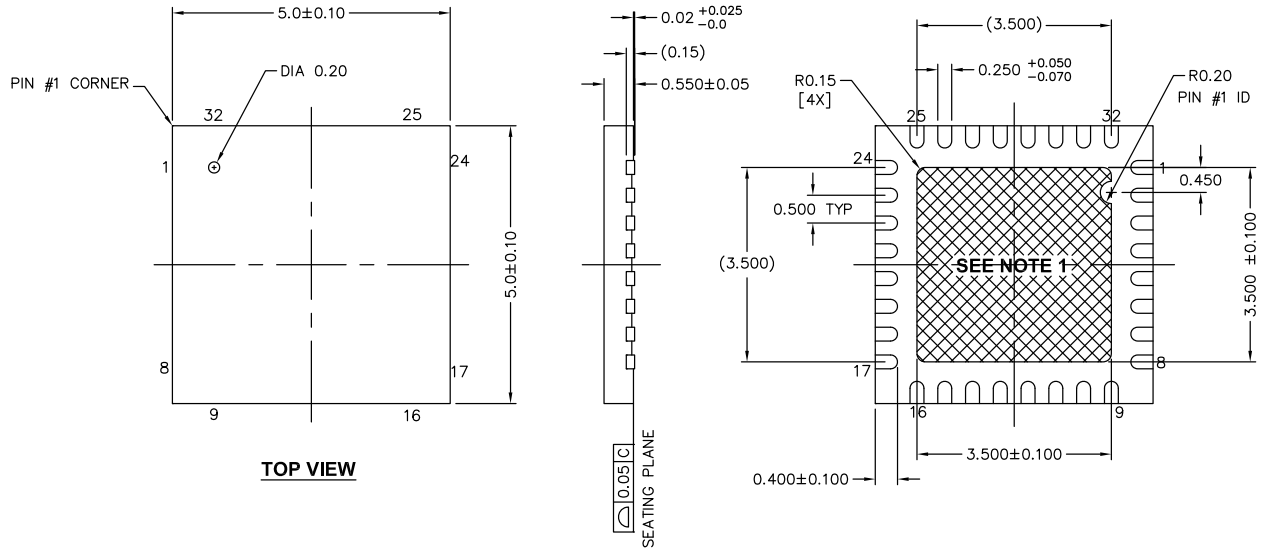

NOTES:

1.  HATCH AREA IS SOLDERABLE EXPOSED PAD
2. BASED ON REF JEDEC # MO-248
3. PACKAGE WEIGHT: 0.0388g
4. DIMENSIONS ARE IN MILLIMETERS

SIDE VIEW

BOTTOM VIEW

001-42168 *E

Figure 15. 48-pin QFN (7 × 7 × 1 mm) LT48A 5.1 × 5.1 E-Pad (Sawn) Package Outline, 001-13191

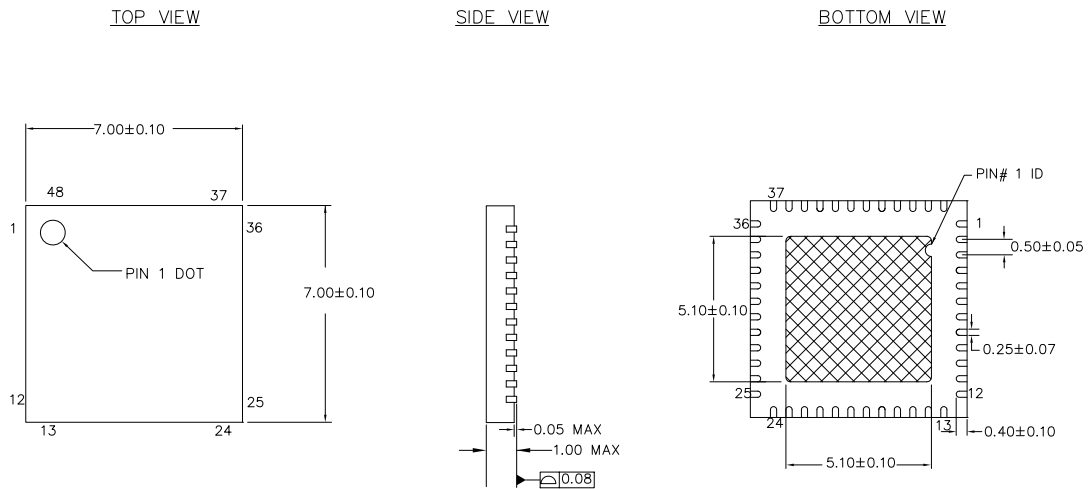

NOTES:

1.  HATCH AREA IS SOLDERABLE EXPOSED METAL.
2. REFERENCE JEDEC#: MO-220
3. PACKAGE WEIGHT: 13 ± 1 mg
4. ALL DIMENSIONS ARE IN MILLIMETERS

001-13191 *G

Package Handling

Some IC packages require baking before they are soldered onto a PCB to remove moisture that may have been absorbed after leaving the factory. A label on the package has details about the actual bake temperature and the minimum bake time to remove this moisture. The maximum bake time is the aggregate time that the parts exposed to the bake temperature. Exceeding this exposure may degrade device reliability.

Table 23. Package Handling

Parameter	Description	Minimum	Typical	Maximum	Unit
TBAKETEMP	Bake Temperature	–	125	See package label	°C
TBAKETIME	Bake Time	See package label	–	72	hours

Thermal Impedances

Package	Typical θ_{JA} ⁽¹⁹⁾
16 QFN	32.69 °C/W
32 QFN ⁽²⁰⁾	19.51 °C/W
48 QFN ⁽²⁰⁾	17.68 °C/W

Capacitance on Crystal Pins

Table 24. Typical Package Capacitance on Crystal Pins

Package	Package Capacitance
32 QFN	3.2 pF
48 QFN	3.3 pF

Solder Reflow Peak Temperature

Following is the minimum solder reflow peak temperature to achieve good solderability.

Package	Minimum Peak Temperature ⁽²¹⁾	Maximum Peak Temperature
16 QFN	240 °C	260 °C
32 QFN	240 °C	260 °C
48 QFN	240 °C	260 °C

Notes

19. $T_J = T_A + \text{Power} \times \theta_{JA}$.

20. To achieve the thermal impedance specified for the package, solder the center thermal pad to the PCB ground plane.

21. Higher temperatures may be required based on the solder melting point. Typical temperatures for solder are 220 ± 5 °C with Sn-Pb or 245 ± 5 °C with Sn-Ag-Cu paste. Refer to the solder manufacturer specifications.

Ordering Information

Ordering Code	Package Information	Flash	SRAM	No. of GPIOs	Target Applications
CY7C60413-16LKXC	16-Pin QFN (3x3 mm)	8 K	1 K	13	Feature-rich wireless mouse
CY7C60413-16LKXCT	16-Pin QFN - (Tape and Reel) (3X3 mm)	8 K	1 K	13	Feature-rich wireless mouse
CY7C60445-32LQXC	32-Pin QFN (5x5x0.55 mm)	16 K	1 K	28	Feature-rich wireless mouse
CY7C60445-32LQXCT	32-Pin QFN - (Tape and Reel) (5x5x0.55 mm)	16 K	1 K	28	Feature-rich wireless mouse
CY7C60455-48LTXC	48-Pin QFN (7x7x0.9 mm)	16 K	1 K	36	Mid-tier wireless keyboard
CY7C60455-48LTXCT	48-Pin QFN - (Tape and Reel) (7x7x0.9 mm)	16 K	1 K	36	Mid-tier wireless keyboard
CY7C60456-48LTXC	48-Pin QFN (7x7x0.9 mm)	32 K	2 K	36	Feature-rich wireless keyboard
CY7C60456-48LTXCT	48-Pin QFN - (Tape and Reel) (7x7x0.9 mm)	32 K	2 K	36	Feature-rich wireless keyboard

Ordering Code Definitions

CY 7 C XXXXX XX X CT

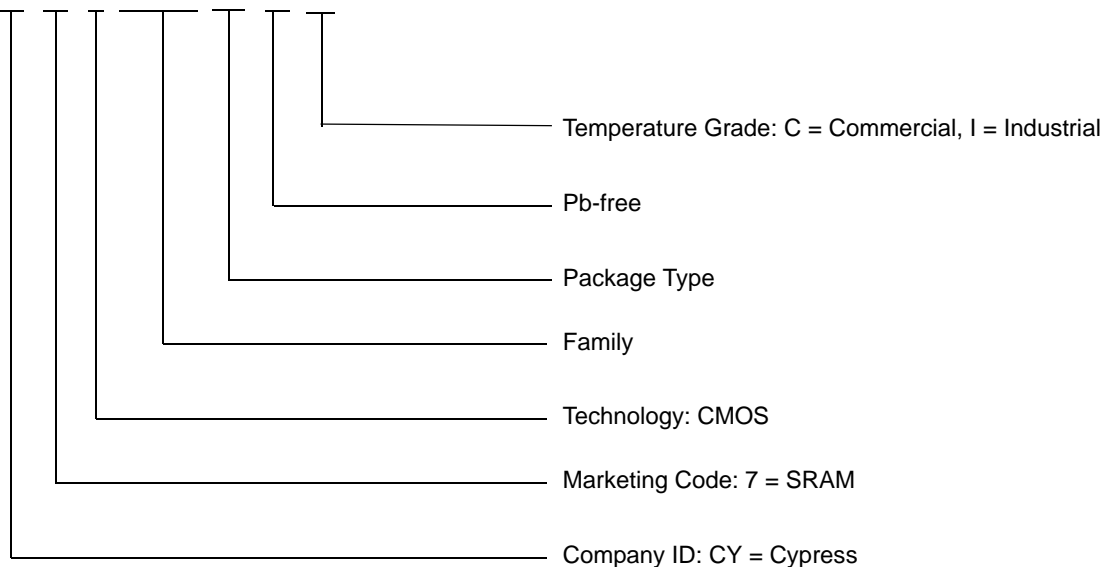

Acronyms

The following table lists the acronyms that are used in this document.

Acronym	Description
API	application programming interface
CPU	central processing unit
GPIO	general purpose IO
ICE	in-circuit emulator
ILO	internal low speed oscillator
IMO	internal main oscillator
I/O	input/output
LSb	least significant bit
LVD	low voltage detect
MSb	most significant bit
POR	power on reset
PPOR	precision power on reset
PSoC	Programmable System-on-Chip
SLIMO	slow IMO
SRAM	static random access memory

Document Conventions

Units of Measure

The following table lists the units of measure that are used in this document.

Symbol	Unit of Measure
°C	degree Celsius
dB	decibels
fF	femto farad
Hz	hertz
KB	1024 bytes
Kbit	1024 bits
kHz	kilohertz
kΩ	kilohm
MHz	megahertz
MΩ	megaohm
μA	microampere
μF	microfarad
μH	microhenry
μs	microsecond
μV	microvolts
μVrms	microvolts root-mean-square
μW	microwatts
mA	milli-ampere
ms	milli-second
mV	milli-volts
nA	nanoampere
ns	nanosecond
nV	nanovolts
W	ohm
pA	picoampere
pF	picofarad
pp	peak-to-peak
ppm	parts per million
ps	picosecond
sps	samples per second
σ	sigma: one standard deviation
V	volts

Errata

This section describes the errata for the enCoRe V – CY7C643xx and enCoRe V LV – CY7C604xx. Details include errata trigger conditions, scope of impact, available workaround, and silicon revision applicability.

Contact your local Cypress Sales Representative if you have questions.

CY7C604xx Errata Summary

The following Errata item applies to the **CY7C643xx** and **CY7C604xx** data sheets.

1. Latch up susceptibility when maximum I/O sink current exceeded

■ **PROBLEM DEFINITION**

P1[3], P1[6], and P1[7] pins are susceptible to latch up when the I/O sink current exceeds 25 mA per pin on these pins.

■ **PARAMETERS AFFECTED**

LU – Latch up current. Per JESD78A, the maximum allowable latch up current per pin is 100 mA. Cypress internal specification is 200 mA latch up current limit.

■ **TRIGGER CONDITIONS**

Latch up occurs when both the following conditions are met:

- A. The offending I/O is externally connected to a voltage higher than the I/O high state, causing a current to flow into the pin that exceeds 25 mA.
- B. A Port1 I/O (P1[1], P1[4], and P1[5] respectively) adjacent to the offending I/O is connected to a voltage lower than the I/O low state. This causes a signal that drops below V_{SS} (signal undershoot) and a current greater than 200 mA to flow out of the pin.

■ **SCOPE OF IMPACT**

The trigger conditions outlined in this item exceed the maximum ratings specified in the CY7C643xx and CY7C604xx data sheets.

■ **WORKAROUND**

Add a series resistor $> 300 \Omega$ to P1[3], P1[6], and P1[7] pins to restrict current to within latch up limits.

■ **FIX STATUS**

This issue will be corrected in the next new silicon revision.

Document History Page

Document Title: CY7C604XX, enCoRe™ V Low Voltage Microcontroller Document Number: 001-12395				
Rev.	ECN No.	Orig. of Change	Submission Date	Description of Change
**	626516	TYJ	See ECN	New data sheet
*A	735721	TYJ / ARI	See ECN	Added new block diagram, replaced TBDs, corrected values, updated pinout information, changed part number to reflect new specifications.
*B	1120504	ARI	See ECN	Corrected the description to pin 29 on Table 1, the Typ/Max values for I _{SB0} on the DC chip-level specifications, and the Min voltage value for V _{ddIWRITE} in the DC Programming Specifications table. Corrected Flash Write Endurance minimum value in the DC Programming Specifications table. Corrected the Flash Erase Time max value and the Flash Block Write Time max value in the AC Programming Specifications table. Implemented new latest template.
*C	1225864	AESA / ARI	See ECN	Corrected the description to pin 13, 29 on Table 1 and 22,44 on Table 2. Added sections Register Reference, Register Conventions and Register Mapping Tables. Corrected Max values on the DC Chip-Level Specifications table.
*D	1446763	AESA	See ECN	Changed T _{ERASEB} parameter, max value to 18ms in Table 13, AC Programming Specification.
*E	1639963	AESA	See ECN	Post to www.cypress.com
*F	2138889	TYJ / PYRS	See ECN	Updated Ordering Code table: - Ordering code changed for 32-QFN package: From -32LKXC to -32LTXC - Added a new package type – “LTXC” for 48-QFN - Included Tape and Reel ordering code for 32-QFN and 48-QFN packages Changed active current values at 24, 12 and 6MHz in table “DC Chip-Level Specifications” - IDD24: 2.15 to 3.1mA - IDD12: 1.45 to 2.0mA - IDD6: 1.1 to 1.5mA Added information on using P1[0] and P1[1] as the I2C interface during POR or reset events

Document History Page (continued)

Document Title: CY7C604XX, enCoRe™ V Low Voltage Microcontroller Document Number: 001-12395				
Rev.	ECN No.	Orig. of Change	Submission Date	Description of Change
*G	2583853	TYJ / PYRS / HMT	10/10/08	<p>Converted from Preliminary to Final ADC resolution changed from 10-bit to 8-bit On Page1, SPI Master and Slave – speeds changed Rephrased battery monitoring clause in page 1 to include “with external components” Included ADC specifications table Voh5, Voh7, Voh9 specs changed Flash data retention – condition added to Note [15] Input leakage spec changed to 25 nA max Under AC Char, Frequency accuracy of ILO corrected GPIO rise time for ports 0,1 and ports 2,3 made common AC Programming specifications updated Included AC Programming cycle timing diagram AC SPI specification updated Spec change for 32-QFN package Input Leakage Current maximum value changed to 1 uA Maximum specification for V_{OH5A} parameter changed from 2.0 to 2.1V Minimum voltages for F_{SPIM} and F_{SPIS} specifications changed from 1.8V to 1.71V (Table 18) Updated V_{OHV} parameter in Table 13 Updated Thermal impedance values for the packages - Table 20. Update Development Tools, add Designing with PSoC Designer. Edit, fix links and table format. Update TMs. Update maximum data in Table 12. DC POR and LVD Specifications.</p>
*H	2653717	DVJA / PYRS	02/04/09	<p>Changed master page from CY7C60445, CY7C6045X to CY7C604XX. Updated Features, Functional Overview, Development Tools, and Designing with PSoC Designer sections. Removed ‘GUI - graphical user interface’ from Document Conventions acronym table. Added Figure 1 and Table 1 (16-pin part information) to Pin Configurations section. Removed ‘O - Only a read/write register or bits’ in Table 4 Edited Table 8: removed 10-bit resolution information and corrected units column. Added Figure 9 (16-pin part information) to Package Dimensions section. Added ‘Package Handling’ section. Added 8K part ‘CY7C60413-16LKXC’ to Ordering Information.</p>
*I	2714694	DVJA / AESA	06/04/2009	<p>Updated Block Diagram. Added 10-bit ADC, SPI, and I2C Slave sections. ADC Resolution changed from 8-bit to 10-bit Updated Figure 9: 5.7 MHz minimum CPU frequency Updated Table 15 AC Chip Level Specs Figure 8: Changed minimum CPU Frequency from 750 kHz to 5.7 MHz</p>
*J	2764460	DVJA / AESA	09/15/2009	<p>Added footnote #5 to Table 10: DC Chip Level Specs Added F_{32K2} (Untrimmed) spec to Table 17: AC Chip level Specs Changed T_{RAMP} spec to SR_{POWER_UP} in Table 17: AC Chip Level Specs Changed Table 14: ADC Specs Added Table 25: Typical Package Capacitance on Crystal Pins</p>
*K	2811903	DVJA	11/23/2009	<p>Added Note 6 on page 18. Changed V_{IHP} in Table 15 on page 22</p>
*L	3075921	NXZ	11/01/2010	<p>Added Ordering Code Definition.</p>
*M	3283876	DIVA	06/15/2011	<p>Updated Getting Started, Development Tools, and Designing with PSoC Designer.</p>

Document History Page (continued)

Document Title: CY7C604XX, enCoRe™ V Low Voltage Microcontroller Document Number: 001-12395				
Rev.	ECN No.	Orig. of Change	Submission Date	Description of Change
*N	3980412	CSAI	04/24/2013	Updated Packaging Dimensions : spec 001-09116 – Changed revision from *E to *H. spec 001-42168 – Changed revision from *D to *E. spec 001-13191 – Changed revision from *E to *G. Added Errata .
*O	4074141	CSAI	07/23/2013	Added Errata footnote (Note 7). Updated Electrical Specifications : Updated DC Electrical Characteristics : Updated DC General Purpose I/O Specifications [7] : Added Note 7 and referred the same note in the heading. Updated Errata . Updated in new template.
*P	4189348	CSAI	11/12/2013	Updated Packaging Dimensions : spec 001-09116 – Changed revision from *H to *I. Completing Sunset Review.

Sales, Solutions, and Legal Information

Worldwide Sales and Design Support

Cypress maintains a worldwide network of offices, solution centers, manufacturer's representatives, and distributors. To find the office closest to you, visit us at [Cypress Locations](#).

Products

Automotive	cypress.com/go/automotive
Clocks & Buffers	cypress.com/go/clocks
Interface	cypress.com/go/interface
Lighting & Power Control	cypress.com/go/powerpsoc cypress.com/go/plc
Memory	cypress.com/go/memory
PSoC	cypress.com/go/psoc
Touch Sensing	cypress.com/go/touch
USB Controllers	cypress.com/go/USB
Wireless/RF	cypress.com/go/wireless

PSoC[®] Solutions

psoc.cypress.com/solutions
PSoC 1 | PSoC 3 | PSoC 4 | PSoC 5LP

Cypress Developer Community

[Community](#) | [Forums](#) | [Blogs](#) | [Video](#) | [Training](#)

Technical Support

cypress.com/go/support

© Cypress Semiconductor Corporation, 2006-2013. The information contained herein is subject to change without notice. Cypress Semiconductor Corporation assumes no responsibility for the use of any circuitry other than circuitry embodied in a Cypress product. Nor does it convey or imply any license under patent or other rights. Cypress products are not warranted nor intended to be used for medical, life support, life saving, critical control or safety applications, unless pursuant to an express written agreement with Cypress. Furthermore, Cypress does not authorize its products for use as critical components in life-support systems where a malfunction or failure may reasonably be expected to result in significant injury to the user. The inclusion of Cypress products in life-support systems application implies that the manufacturer assumes all risk of such use and in doing so indemnifies Cypress against all charges.

Any Source Code (software and/or firmware) is owned by Cypress Semiconductor Corporation (Cypress) and is protected by and subject to worldwide patent protection (United States and foreign), United States copyright laws and international treaty provisions. Cypress hereby grants to licensee a personal, non-exclusive, non-transferable license to copy, use, modify, create derivative works of, and compile the Cypress Source Code and derivative works for the sole purpose of creating custom software and/or firmware in support of licensee product to be used only in conjunction with a Cypress integrated circuit as specified in the applicable agreement. Any reproduction, modification, translation, compilation, or representation of this Source Code except as specified above is prohibited without the express written permission of Cypress.

Disclaimer: CYPRESS MAKES NO WARRANTY OF ANY KIND, EXPRESS OR IMPLIED, WITH REGARD TO THIS MATERIAL, INCLUDING, BUT NOT LIMITED TO, THE IMPLIED WARRANTIES OF MERCHANTABILITY AND FITNESS FOR A PARTICULAR PURPOSE. Cypress reserves the right to make changes without further notice to the materials described herein. Cypress does not assume any liability arising out of the application or use of any product or circuit described herein. Cypress does not authorize its products for use as critical components in life-support systems where a malfunction or failure may reasonably be expected to result in significant injury to the user. The inclusion of Cypress' product in a life-support systems application implies that the manufacturer assumes all risk of such use and in doing so indemnifies Cypress against all charges.

Use may be limited by and subject to the applicable Cypress software license agreement.